

Hot dip galvanized crane forks with adjustable forks

Product information



For handling of standard pallets from the long side. Thanks to the spring-loaded lifting eye, the pallet fork is self-balancing, which means that the forks are always horizontal, regardless of whether the pallet fork is empty or loaded.

... [Read more](#)

Material: Beam and plate of high-strength structural steel

Finish: Hot dip galvanized

Hot dip galvanized crane forks with adjustable forks

Blueprint

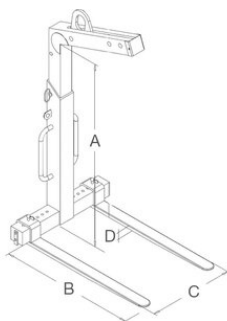

Technical data

Part code	WLL ton	A mm	B mm	C mm	D mm	Weight kg
6201NOH1500SKS	1.5	1300-2000	1,000	350-900	40	142
6201NOH1500SKS	3	1300-2000	1,000	450-900	50	260

Hot dip galvanized crane forks with adjustable forks

SPARE PARTS

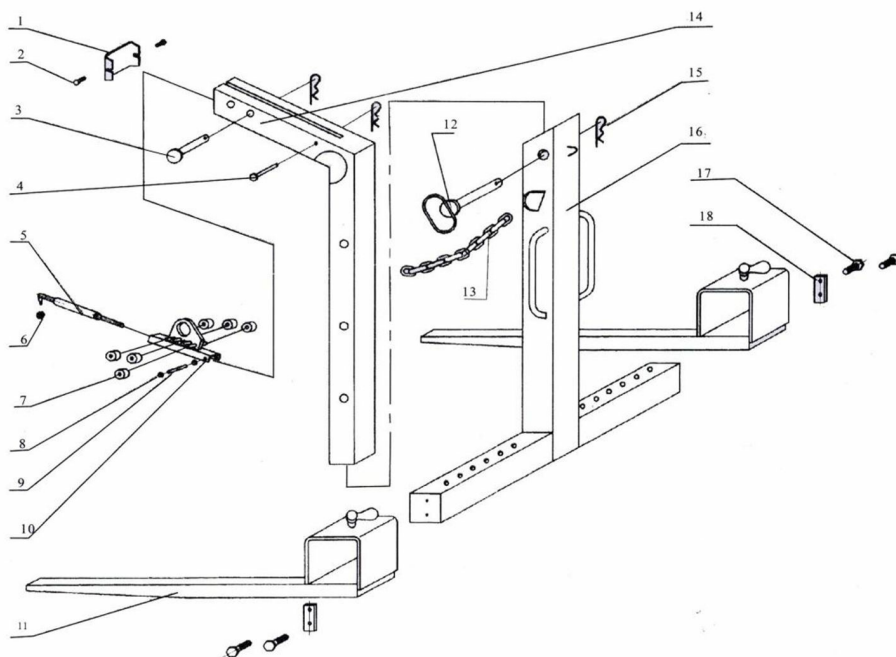

Spare part (product code)	Description	Suitable for crane fork (product code)
NOH1500SKAJ	Gas spring for crane fork Part no. 5	NOH1500SKS
NOH3000SKAJ	Gas spring for crane fork Part no. 5	NOH3000SKS

Also other spare parts available with a delivery time, ask our sales for more information