

Chain Block POWERTEX PCB-S2OLP with electrogalvanized chain

Product information



The Powertex PCB-S2 OLP Chain Hoist is a high-quality chain block designed to provide durability, safety, and ease of operation. With its ergonomic hand chain, advanced features, and built-in overload protection, this chain hoist ensures smooth and efficient lifting for various industrial applications. This OLP version has an integrated Overload Protection, which ensures safe lifting and prevents unintended overloading of the hoist.

Product benefits:

- **Overload protection device:** the OLP hoists are factory-equipped with an Overload Protection device, which limits the maximum operating force that can be applied using the hand chain, ensuring safe and controlled lifting operations.
- **Enhanced safety:** each hoist undergoes dynamic proof load testing at 1.5 times the Working Load Limit (WLL) before leaving the factory, ensuring maximum safety and reliability. The hoist is equipped with a well-covered automatic load reaction brake and features double safety with two brake pawls and four brake springs, exceeding EN 13157 requirements. The load chain is calibrated, proof load tested and meets the requirements of EN 818-7.
- **Smooth and efficient operation:** the compact and lightweight construction, combined with a sprocket wheel equipped with needle bearings and a drive shaft supported by needle and slide bearings, ensures smooth and efficient operation. The fine-calibrated load chain offers quiet and seamless performance.
- **Quality load chain:** the load chain complies with the EN818-7 T(8) standard and features a Chrome 6-free electro-galvanized surface finish to protect it from corrosion.

[... Read more](#)

Material: Durable all steel construction

Marking: According to standard, CE-marked, UKCA-marked, POWERTEX, Model, WLL, Chain, Serial number, User manual/QR code

Temperature range: -10°C up to +50°C

Finish: Red powder coated body and plated frame components

Standard: EN 13157, EN 818-7

Safety factor: 4:1

Chain Block POWERTEX PCB-S2OLP with electrogalvanized chain

Blueprint

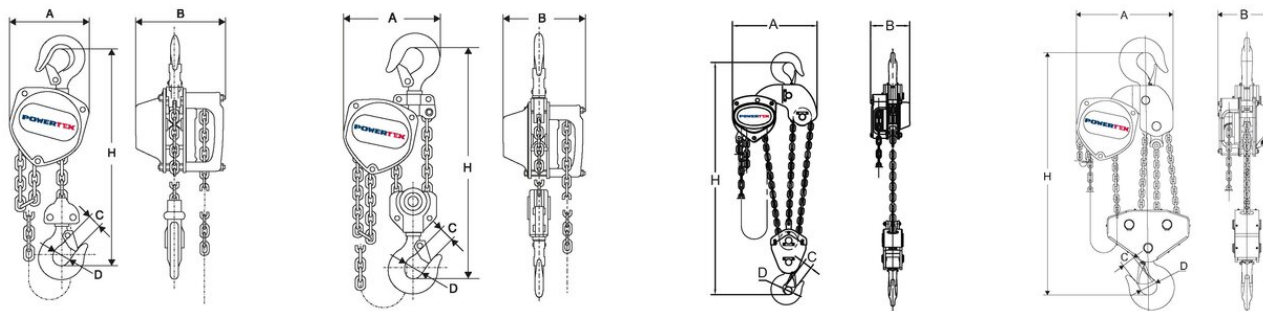

Technical data

Part code	WLL ton	Lifting height m	Number of falls	Model	Load chain mm	Hand chain mm	Hand force max. kg	A mm	B mm	C mm	D mm	H min mm	Weight kg
500100050300681	0.5	3	1	PCB-S2OLP/500KG PHCA	5,0 x 15,0	5,0 x 23,7	24.9	130	128	22	34	280	9.8
500100050600681	0.5	6	1	PCB-S2OLP/500KG PHCA	5,0 x 15,0	5,0 x 23,7	24.9	130	128	22	34	280	9.8
500100100300681	1	3	1	PCB-S2OLP/1000KG PHCA	6,3 x 19,0	5,0 x 23,7	28.4	150	145	26	39	330	11.7
500100100600681	1	6	1	PCB-S2OLP/1000KG PHCA	6,3 x 19,0	5,0 x 23,7	28.4	150	145	26	39	330	12
500100100500681	1	5	1	PCB-S2OLP/1000KG PHCA	6,3 x 19,0	5,0 x 23,7	28.4	150	145	26	39	330	15.2
500100200300681	2	3	1	PCB-S2OLP/2000KG PHCA	8,0 x 24,0	5,0 x 23,7	34.3	185	175	35	49	385	18.9
500100200600681	2	6	1	PCB-S2OLP/2000KG PHCA	8,0 x 24,0	5,0 x 23,7	34.3	185	175	35	49	385	19.5
500100300300681	3	3	2	PCB-S2OLP/3000KG PHCA	7,1 x 21,0	5,0 x 23,7	34.3	220	158	37	50	510	28.9
500100300600681	3	6	2	PCB-S2OLP/3000KG PHCA	7,1 x 21,0	5,0 x 23,7	34.3	220	158	37	50	510	28.9
500100500300681	5	3	2	PCB-S2OLP/5000KG PHCA	9,0 x 27,0	5,0 x 23,7	37.2	255	183	43	60	615	37.1
500100500600681	5	6	2	PCB-S2OLP/5000KG PHCA	9,0 x 27,0	5,0 x 23,7	37.2	255	183	43	60	615	51.05
500100750300681	7.5	3	3	PCB-S2OLP/7500KG PHCA	9,0 x 27,0	5,0 x 23,7	36.8	430	189	47	67	690	50
500100750600681	7.5	6	3	PCB-S2OLP/7500KG PHCA	9,0 x 27,0	5,0 x 23,7	36.8	430	189	47	67	690	66.2
500101000300681	10	3	4	PCB-S2OLP/10000KG PHCA	9,0 x 27,0	5,0 x 23,7	40	360	183	47	65	820	92.8
500101000600681	10	6	4	PCB-S2OLP/10000KG PHCA	9,0 x 27,0	5,0 x 23,7	40	360	183	47	65	820	114.4