

GWK mobile work shop cranes

Product information



REMA[®]

Robust construction, easy functioning. Specially for intensive working environments

Properties

- Collapsible easy to transport.
- Robust construction.
- Hard chromed cylinder.
- Braked steering wheels can be rotated 360 °.
- Rotating load hook (not under load).
- Lever adjustable in 3 positions.
- 125% proofed.
- Safety valve against overload.
- GWK-1000 has extra long legs.

... [Read more](#)

Marking: According to standard, CE-marked

Standard: EN 12100, EN 14985

GWK mobile work shop cranes

Blueprint

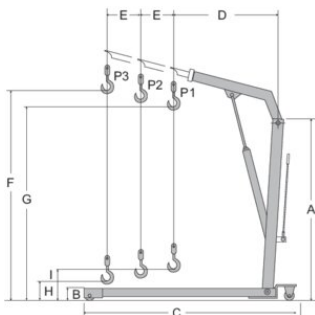

Technical data

Part code	GTIN No.	WLL	Model	Width mm	WLL P1kg mm	WLL P2kg mm	WLL P3kg mm	A mm	B mm	C mm	D mm	E mm	F mm	G, mm	H, mm	Imm mm	Weight
R4220015	8717365020476	0.5	GWK-500	970	500	425	350	1,410	165	1,510	895	102	2,120	1,960	130	340	75
R4220017	8717365020483	1	GWK-1000	1,120	1,000	800	700	1,675	90	1,630	1,230	150	2,445	2,330	-	245	115
R4220019	8717365019524	2	GWK-2000	1,165	2,000	1,700	1,500	1,690	205	1,900	1,290	150	2,705	2,505	-	230	165