

RMH hydraulic machine jack

Product information



REMA[®]

Properties

- Compact and stable construction.
- Usable in any position.
- Very low foot.
- The housing can be rotated through 360 °.
- Accurate adjustment of the lowering speed.
- prevented from overload.
- Patented construction.
- The pump handle is detachable.

Application

- Designed for repair, maintenance and mounting of heavy machines.
- The claw is deployable in various positions relative to the base and pump unit.

IMPORTANT:

- Never exceed the safe working load of the machine lifter.
- Never subject the claw to point loading, always fully load.
- Never add an additional load with a raised load.
- Do not use in unstable and uncertain positions.
- Use only with a flat surface that can carry the load.
- The load must be stable during lifting.
- Do not use machine lifters that are in bad condition or damaged.
- Ensure that the machine lifters are inspected and approved by a competent authority every year.
- It is not allowed to lift people with machine lifters.

... [Read more](#)

Marking: According to standard, CE-marked
Standard: EN 12100, EN 1494

RMH hydraulic machine jack

Blueprint

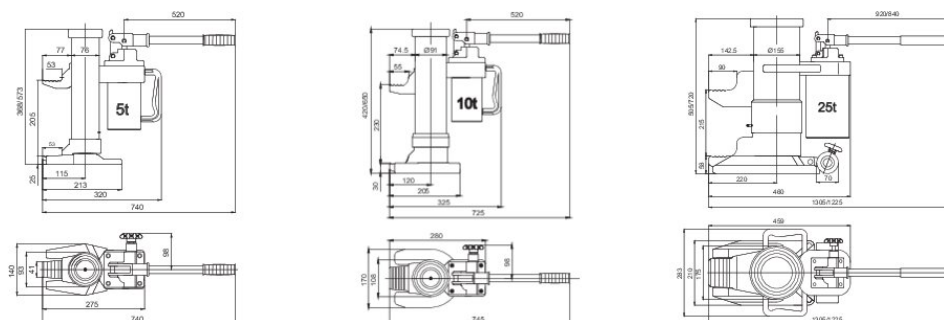

Technical data

Part code	GTIN No.	WLL ton	Model	Hand force max. kg	Weight kg
52051800050	8717365020377	5	RMH-50	38	25
52051800100	8717365008498	10	RMH-100	40	35
52051800250	8717365008504	25	RMH-250	40	102