

Lever Hoist Elephant YA mini (Rema YAM)

Product information



The Elephant YA mini lever hoist is compact and a very low own weight. The required manual effort on the short handle (180 mm) remains low because the YAM is equipped with a gear transmission. The ideal tool for assembly work such as hoisting, pulling and tensioning.

Features:

- Very low self weight (2,8 kg), compact.
- Hooks equipped with safety latches.
- Self locked brake holds the load at any desired height.
- Freewheel is possible in unloaded condition, by 1 operation.
- Hoist fitted with rubber anti-slip handle.
- In case of overload, the hooks will gradually bend and do not suddenly break off.
- Galvanized load chain Grade 10.

Standard delivery:

- 1,5 m lifting height (max. distance between top & bottom hooks).

Option:

- Available in other lifting heights.

... [Read more](#)

Marking: According to standard, CE-marked

Standard: EN 818-7, EN 13157

Lever Hoist Elephant YA mini (Rema YAM)

Blueprint

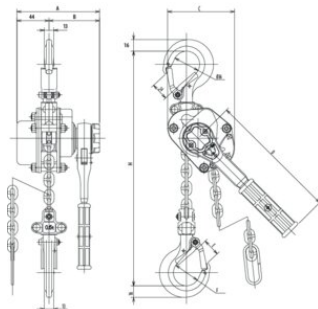

Technical data

| Part code | WLL ton | Lifting height m | Number of falls | Model | Load chain mm | Construction height mm | Hand force max. kg | A mm | B mm | C mm | D mm | E mm | F mm | H mm | Weight kg |
|-----------------|---------|------------------|-----------------|---------------|---------------|------------------------|--------------------|------|------|------|------|------|------|------|-----------|
| 500500050150370 | 0.5 | 1.5 | 1 | YAM-500KG-1,5 | 4.3 x 12 | 240 | 35 | 113 | 69 | 92 | 180 | 24 | 36 | 240 | 2.8 |
| 500500050300370 | 0.5 | 3 | 1 | YAM-500KG-3 | 4.3 x 12 | 240 | 35 | 113 | 69 | 92 | 180 | 24 | 36 | 240 | 3.4 |
| 500500050450370 | 0.5 | 4.5 | 1 | YAM-500KG-4,5 | 4.3 x 12 | 240 | 35 | 113 | 69 | 92 | 180 | 24 | 36 | 240 | 4 |
| 500500050600370 | 0.5 | 6 | 1 | YAM-500KG-6 | 4.3 x 12 | 240 | 35 | 113 | 69 | 92 | 180 | 24 | 36 | 240 | 4.6 |